

Price: \$25.00

**OPERATING MANUAL
X150 COMPACT, INTEGRATED
DC POWER SYSTEM**

Manual No. X150-203-1
10/29/03 X150-standardMan.p65

© copyright 2003 UNIPOWER Corp.
All Rights Reserved

UNIPOWER Telecom, Division of UNIPOWER Corporation

ILLUSTRATIONS

FIGURE	TITLE	PAGE
1	Gravitas X150 Compact, Integrated DC Power System	2
2	Gravitas X150 with Distribution Section Cover	2
3	The Power Distribution Section	7
4	Rear View of Connections to DIN-Rail Terminal Blocks	7
5	Analog and Digital Controllers	9
6	Gravitas X150 Simplified Block Diagram	9
7	Gravitas X150 Connection Terminals	13
8	Gravitas X150 Signal Interface Connections	13

CONTENTS

SECTION	TOPIC	PAGE
1.0	Introduction	1
2.0	General Description	1
3.0	Gravitas X150 Summary Features	3
4.0	Summary of X150 System Capability	4
5.0	Rectifier Summary and Specifications	4
6.0	Power Distribution Section	6
7.0	Controller Section	8
8.0	Safety Warnings and Precautions	10
9.0	Warranty	10
10.0	Unpacking and Inspection	11
11.0	Description of Operation	11
12.0	Installation	12
13.0	Introduction to Control and Monitoring	15
14.0	Analog Controller Front Panel Description	15
15.0	Signal Input/Output Connections	16
16.0	Analog Controller LED Indicators	16
17.0	Front Panel Adjustment Potentiometers	16
18.0	Description of Analog Controller Operation	16
19.0	Controller Signal Connections	17
20.0	Battery Temperature Compensation (Option)	19
21.0	Alarm Enabling	20
22.0	Voltage and Current Measurements	21
23.0	Maintenance	21
Appendix 1	Gravitas X150 Data Sheet	A1
Appendix 2	Application Note: Three-Phase Power with Unipower Front-Ends and Rectifiers	A2

OPERATING MANUAL

GRAVITAS X150 COMPACT, INTEGRATED DC POWER SYSTEM

1.0 INTRODUCTION

This Operating Manual should be read through carefully before installing and operating the Gravitas X150 Integrated DC Power System.

Connection to this system and servicing it must be performed only by qualified technicians who are trained in the installation and operation of electrical power systems. The safety warning described later must be carefully followed.

Unipower Telecom, a division of Unipower Corporation, does not accept responsibility for safety, reliability or performance of these systems if any modifications or repairs are carried out by unauthorized personnel. Unipower Telecom specified replacement parts must be used and must be of the same type and rating to ensure continued protection against risk of fire.

Since Unipower Telecom has a policy of continued product improvement, specifications and components of this system are subject to change.

2.0 GENERAL DESCRIPTION

2.1 The Gravitas X150 is a compact, integrated DC power system. See Figure 1. It consists of three high power-density, hot-swap rectifier modules which can produce a total 75 amperes at -48VDC, 150 amperes at -48VDC or 150 amperes at +24VDC, depending on system configuration. In a 2+1 redundant operation the output currents are 50, 100 and 100 amperes, respectively. There are five standard models of the X150.

2.2 The complete system has a DC distribution panel with up to 10 load circuits which are protected by circuit breakers, GMT fuses or a combination of the two. Three AC breakers are optional, with one breaker for each rectifier input. Also optional is a low-voltage battery disconnect. Battery breakers for up to three battery strings can be provided.

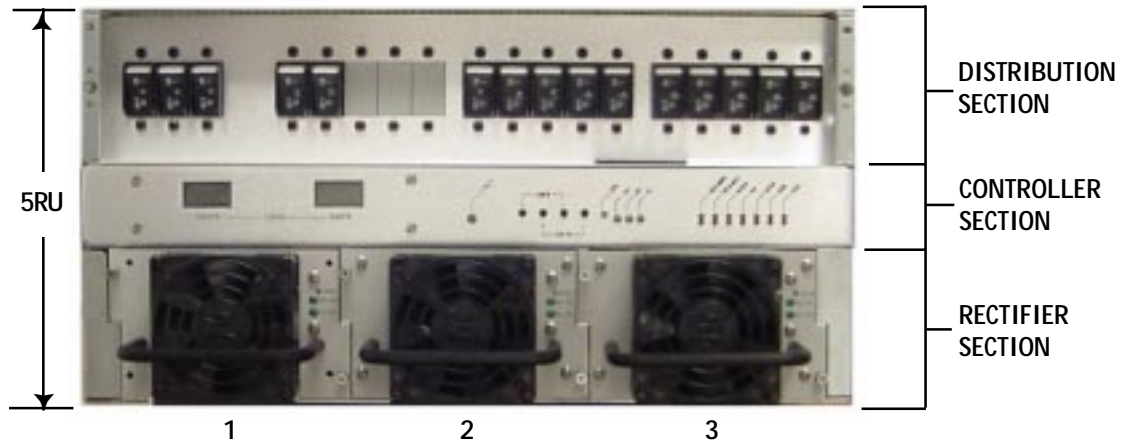

Figure 1. Gravitas X150 Compact, Integrated DC Power System



Figure 2. Gravitas X150 with Distribution Section Cover

- 2.3 There are two choices for the system controller. A standard analog controller has LED visual alarms, Form C relay alarms, test points and set-point adjustments including over- and under-voltage adjustments. There is a temperature compensation option and digital voltage and current display option. An optional digital controller provides all these features in keypad format with an alphanumeric display and remote data access options.
- 2.4 The complete Gravitas X150 is only 5RU high (8.65 inches or 220mm) and is easily installed by a qualified technician. All connections are at the rear to DIN-rail terminal blocks. The units may be mounted in 19- or 23-inch racks. A lock-on cover is provided to cover the distribution section. See Figure 2. A wallet is also provided in this section for recording the DC circuits. See Figure 3.

3.0 GRAVITAS X150 SUMMARY FEATURES

- ◆ Choice of Hot-Swap Rectifiers
- ◆ 120 or 230VAC Input
- ◆ Power Factor Corrected
- ◆ AC Line Breakers Option
- ◆ Class B EMI Input Filter
- ◆ Up to 150A at -48 or +24VDC
- ◆ Up to 100A for 2+1 Redundant
- ◆ Up to 10 DC Circuit Breakers or Fuses
- ◆ Up to 3 Battery Strings
- ◆ Up to 3 Battery String Breakers
- ◆ LV Battery Disconnect Option
- ◆ Analog or Digital Controller
- ◆ Communication Options
- ◆ Distribution Section Cover
- ◆ Distribution Section Wallet
- ◆ Quick, Easy Installation
- ◆ Modular Design
- ◆ Only 5RU (8.65 Inches) High

4.0 SUMMARY OF X150 SYSTEM CAPABILITY

Table 4-1 summarizes the Gravitas X150 overall capability for the four standard models.

Table 4-1 X150 System Capability

SYSTEM CAPABILITY	SYSTEM MODEL NO.				
	X150-48R/150	X150-48R/75	X150-48M/75	X150-24R/150	X150-24M/150
System Voltage	-48VDC	-48VDC	-48VDC	+24VDC	+24VDC
System Max. Current	150A	75A	75A	150A	150A
System Current, 2+1	100A	50A	50A	100A	100A
Input Range, VAC	170-264	85-264	170-264	85-264	170-264
Rectifier Model	RRS48/50	RRP48/25	RMP48/25	RRP24/50	RMP24/50
Rectifiers Required	3	3	3	3	3
Input Breakers, AC ¹	3 optional	3 optional	3 optional	3 optional	3 optional
Battery String Breakers	2 standard	1 standard	1 standard	2 standard	2 standard
Extra Breaker	1 optional	1 optional	1 optional	1 optional	1 optional
LVD, 150 Amp ²	optional	optional	optional	optional	optional
Total No. of DC Loads ³	10	10	10	10	10
1-50A Breakers	4	4	4	4	4
1-20A Breakers	6	6	6	6	6
½-12A GMT Fuses	10	10	10	10	10
Control Features					
Alarm Outputs	7 standard	7 standard	7 standard	7 standard	7 standard
Temp. Compensation	optional	optional	optional	optional	optional
Communications					
LAN	optional	optional	optional	optional	optional
Modem	optional	optional	optional	optional	optional
Local RS232	optional	optional	optional	optional	optional
Rack Height	5RU	5RU	5RU	5RU	5RU
Rack Width, Inches ⁴	19	19	19	19	19

NOTES: 1. One per rectifier module.
 2. Battery disconnect.
 3. May total 12 if no battery string breakers are used. Check with factory.
 4. 23-Inch mounting brackets can be supplied.

5.0 RECTIFIER SUMMARY & SPECIFICATIONS

5.1 The Gravitas X150 rectifier consists of three parallel-connected, hot-swap rectifier modules. There is a choice of five different modules which give the following maximum system capabilities: -48VDC at 75 amperes, -48VDC at 150 amperes and +24VDC at 150 amperes. These capabilities are for non-redundant operation. For 2+1 redundant operation of the modules, the maximum capabilities are: -48VDC at 50 amperes, -48VDC at 100 amperes and +24VDC at 100 amperes.

5.2 The -48 volt and +24 volt outputs are nominal values. The actual adjustment ranges are 45 to 58V and 22.5 to 29V, respectively; the factory-set outputs are -54.4V and +27.2V, respectively. Table 5-1 summarizes the key characteristics of the five rectifier module models.

Table 5-1 Rectifier Module Summary

SPECIFICATIONS	MODULE MODEL NO.				
	RRS48/50	RRP48/25	RMP48/25	RRP24/50	RMP24/50
Output Voltage, Nom.	48VDC	48VDC	48VDC	24VDC	24VDC
Output Voltage, Set	54.4V	54.4V	54.4V	27.2V	27.2V
Output Voltage Range	45-58V	45-58V	45-58V	22.5-29V	22.5-29V
Output Current, Max.	50A	25A	25A	50A	50A
Output Watts, Max.	2,720	1,360	1,360	1,360	1,360
Input Range, VAC	170-264	85-264	170-264	85-264	170-264
Input Power Factor	0.98	0.98	0.99	0.98	0.99
Input Current, 230VAC	14.2A	7.1A	7.1A	7.1A	7.1A
120VAC	-	13.6A	-	13.6A	-
Inrush Current Limit	25A Pk.	25A Pk.	50A Pk.	25A Pk.	50A Pk.
Input Frequency, Hz	47-63	47-63	47-63	47-63	47-63
Efficiency	87%	87%	87%	85%	85%
Total Regulation, Max.	1.0%	1.0%	1.0%	1.0%	1.0%

5.3 Table 5-2 gives the detailed specifications of the rectifier modules.

Table 5-2 Rectifier Module Specifications

INPUT

Voltage Range _____ 85-264 or 170-264VAC
 Power Factor _____ 0.98 or 0.99
 Total Harmonic Distortion, Max. _____ 5%
 Frequency _____ 47-63Hz
 Inrush Current Limiting _____ 25 or 50A Peak
 EMI Filter, Conducted _____ FCC20780 pt. 15J Curve B
 _____ EN55022 Curve B
 Input Immunity, Conducted
 Fast Transients, Line-Line _____ ±2kV (EN61000-4-4 Level 3)
 Surges, Line-Line _____ ±1kV (EN61000-4-5 Level 2)
 Surges, Line-Ground _____ ±2kV (EN61000-4-5 Level 3)

OUTPUT

Output Voltage Set, 48V Nom. _____ 54.4VDC
 24V Nom. _____ 27.2VDC
 Voltage Adjustment Range, 48V Nom. _____ 45-58VDC
 24V Nom. _____ 22.5-29VDC
 Total Regulation, Max. _____ 1.0%
 Holdup Time _____ 20msec.
 Overvoltage Protection, 48V Out _____ 59V
 24V Out _____ 29V

Filtering: Wideband Noise, 20Mhz BW
 48V Out, P-P _____ 500mV
 24V Out, P-P _____ 250mV
 Voice Band Noise _____ <32dBnC
 Current Limit _____ 105% Rated Current
 Efficiency _____ 85-87%

STATUS INDICATORS

AC Good _____ Green LED
 DC Good _____ Green LED

ENVIRONMENTAL

Operating Temp. Range _____ 0°C to +70°C
 Output Current Derating _____ 2.5%/°C, 50°C to 70°C
 Storage Temp. Range _____ -40°C to + 85°C
 Humidity _____ 0% to 95%, Non-Condensing
 ESD _____ Bellcore GR-1089-Core and EN61000-4-2
 Cooling _____ Internal Fans

6.0 POWER DISTRIBUTION SECTION

- 6.1 Figure 3 shows the two versions of the Power Distribution section. On the left the section consists of the three optional 20-ampere AC circuit breakers, one for each rectifier module. Next, to the right are up to three (two is standard, a third optional) 100-ampere battery string circuit breakers. Farther to the right is a set of five DC circuit breakers. The first four of these can be up to 50-ampere capacity; the fifth one can be up to 20-ampere capacity. The second set of five breakers at the right are all up to 20-amperes capacity. Alternatively, the second set of breakers can be replaced by 10 GMT fuses which can range from 1/2A up to 12A each. Maximum total current for the 10 fused loads is 80 amperes.
- 6.2 The total number of DC circuits is limited to 10. This means that any combination of circuit breakers and GMT fuses must not exceed 10 total. Also, the total capacity of all DC circuits is limited to the maximum total current rating of the three rectifier modules.
- 6.3 The Power Distribution Section has a wallet at the right bottom for recording the number and title of each DC load. Additionally, there is a lock-on cover for the Power Distribution section to protect the breakers from any disturbance.
- 6.4 The DC distribution connections are made at the rear of the X150 to DIN-Rail terminal blocks. See Figure 4.

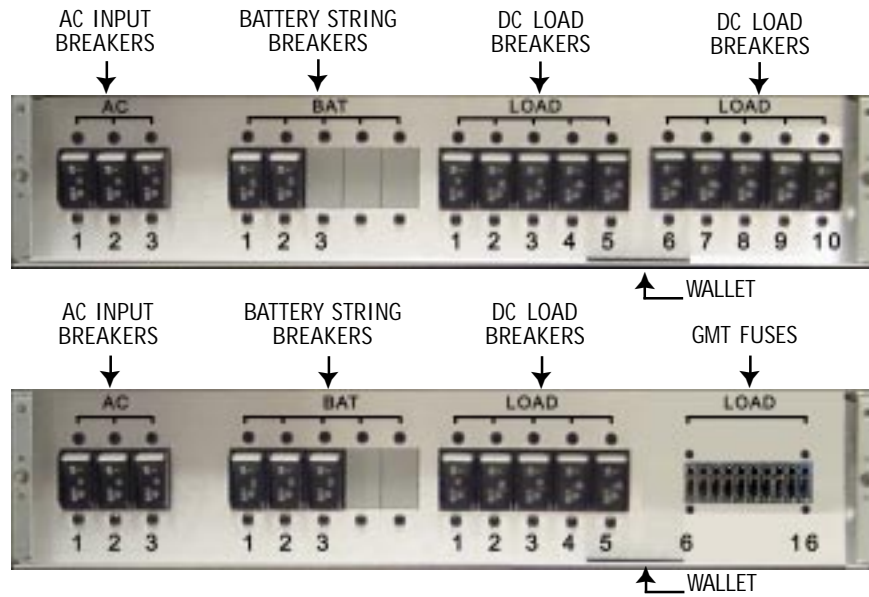

Figure 3. The Power Distribution Section

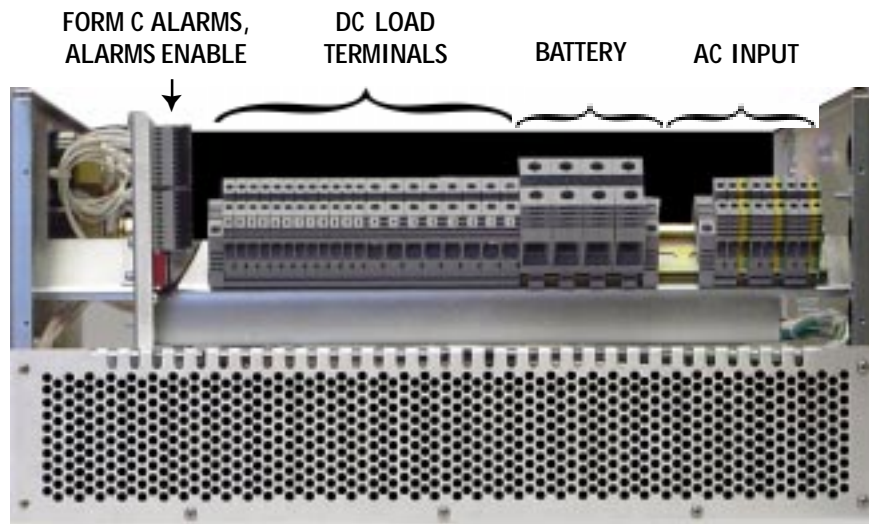

Figure 4. Rear View of Connections to DIN-Rail Terminal Blocks

7.0 CONTROLLER SECTION

7.1 Analog Controller. This analog controller controls the system rectifier, monitors the system parameters and has alarms for system failures. See Figure 5. There are seven red LED alarms which also have Form C relay outputs to indicate a failure:

- ◆ Rectifier-Major
- ◆ Rectifier-Minor
- ◆ AC Input
- ◆ Circuit Breaker or Fuse
- ◆ Low Voltage Disconnect
- ◆ Overvoltage
- ◆ Undervoltage

Four front-panel voltage-set adjustments are for:

- ◆ Float Voltage
- ◆ Battery Overvoltage
- ◆ Battery Undervoltage
- ◆ Temperature Compensation

Test points for load voltage and current permit external measurement of these values. An option for this controller includes digital meters for continuously monitoring battery voltage and load current.

7.2 Digital Controller (Option). This full-featured controller is a control and supervisory unit that communicates directly with the rectifier to monitor and control its function. The digital controller features a keypad and a backlit 2x24 character alphanumeric display. All system parameters can be controlled by the keypad. Alternatively, the system can be controlled by software from a remote PC by means of a standard RS232 port or via an optional modem or Ethernet LAN. This controller also has an optional temperature probe for temperature compensated output from the rectifier.

7.2 Low-Voltage Battery Disconnect (Option). This battery disconnect has a 150-ampere capacity and connects between the rectifier output bus and the battery. The contactor disconnects the battery from the rectifier and loads when the rectifier bus (and battery) voltage drops to 42.5V for a 48V system or 21.25V for 24V system. When the rectifier bus voltage rises above 49V for a 48V system or 24.5V for a 24V system, the contactor reconnects the battery to the rectifier bus.

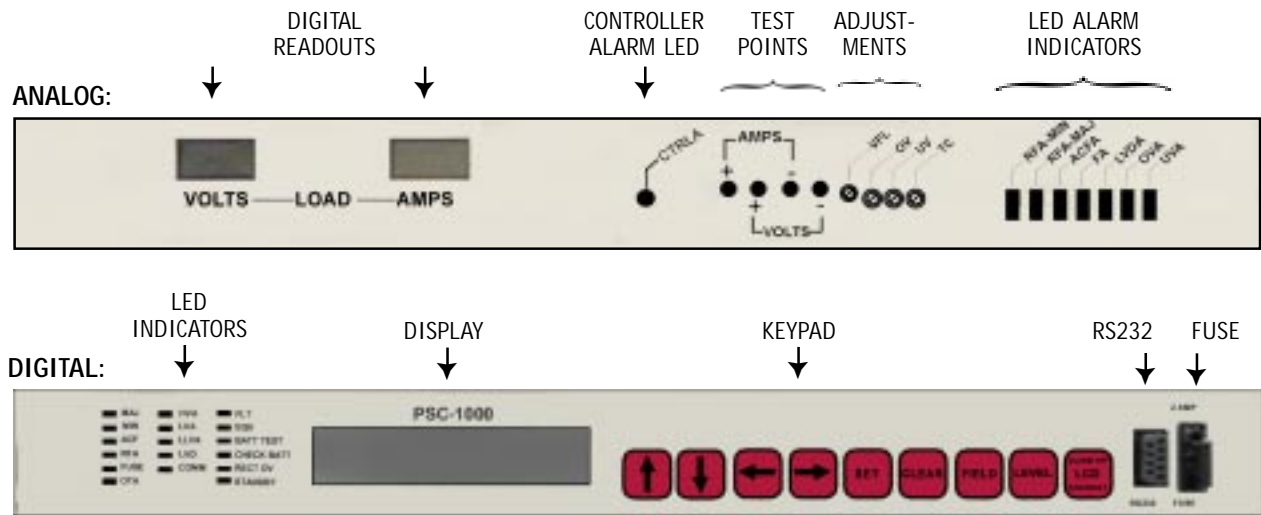

Figure 5. Analog and Digital Controllers

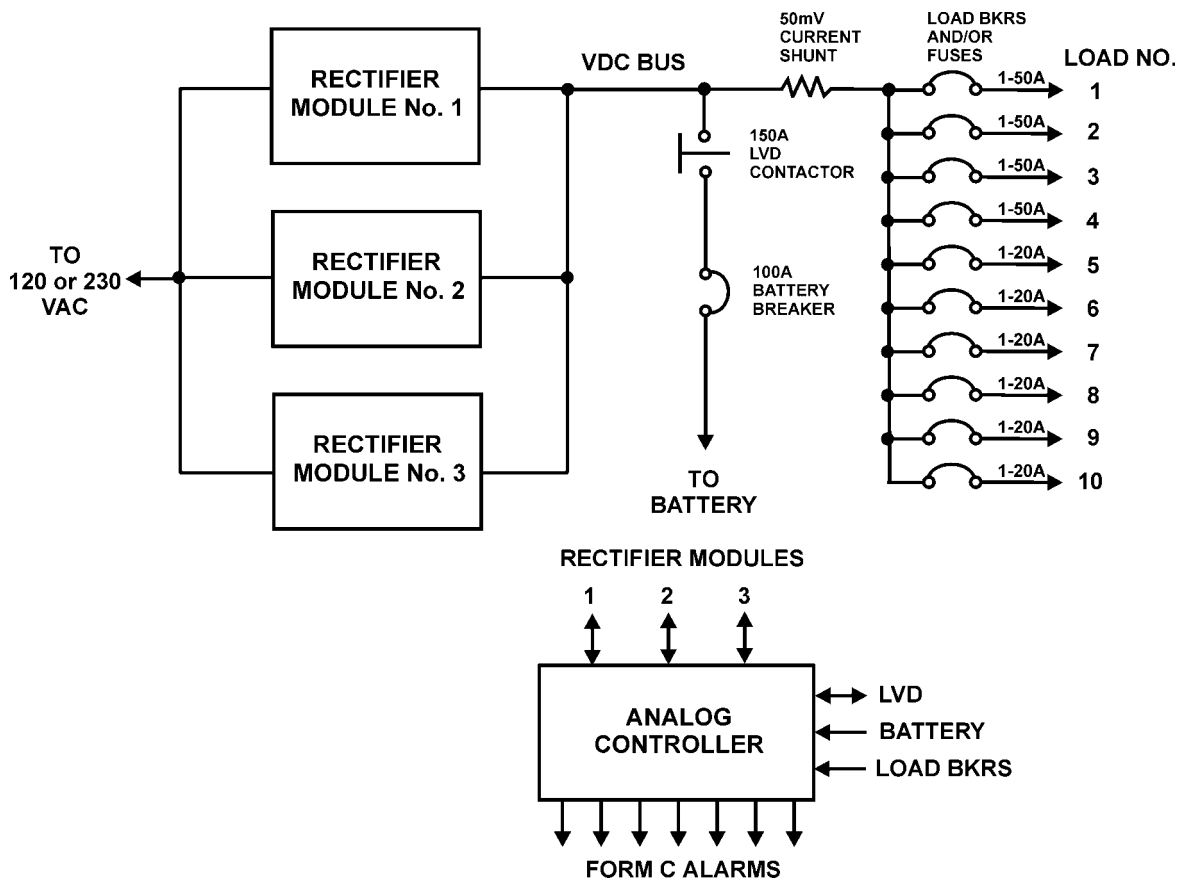

Figure 6. Gravitas X150 Simplified Block Diagram

8.0 SAFETY WARNINGS AND PRECAUTIONS

- 8.1 This Integrated Power System must be handled, installed and maintained only by qualified technical persons who are trained in the installation and use of power systems and are well aware of the hazards involved with these systems.
- 8.2 **WARNING: This power system has hazardous external and internal voltages; the system also has high earth leakage current. The AC input voltage of 85 to 264VAC is hazardous, and the output voltages of 45 to 58VDC or 22.5 to 29VDC are hazardous. Touching either input or output terminals while the system is connected and operating could cause serious injury or death. Internal assemblies are also hazardous and should not be touched.**
- 8.3 Covers on internal assemblies should not be removed. There are no user-serviceable components in these assemblies. Removing the covers of these assemblies will void the warranty.
- 8.4 Installation connections should be made without input power applied, without battery power applied and without other power sources applied to the load.
- 8.5 The chassis should be connected to the system frame ground terminal and a three-wire AC power line with ground connection should be used to minimize electrical shock hazard and ensure low EMI (electromagnetic interference).
- 8.6 This operating manual should be read carefully and understood before attempting installation or testing.

9.0 WARRANTY

All products of UNIPOWER Telecom, a division of UNIPOWER Corporation, are warranted for two (2) years from date of shipment against defects in material and workmanship. This warranty does not extend to products which have been opened, altered or repaired by persons other than persons authorized by the manufacturer or to products which become defective due to acts of God, negligence or the failure of customer to fully follow instructions with respect to installation, application or maintenance. This warranty is extended directly by the manufacturer to the buyer and is the sole warranty applicable. EXCEPT FOR THE FOREGOING EXPRESS WARRANTY, THE MANUFACTURER MAKES NO WARRANTY, EXPRESS OR IMPLIED, INCLUDING, BUT NOT LIMITED TO, THE WARRANTY OF MERCHANTABILITY OR FITNESS FOR A PARTICULAR PURPOSE. As the sole and exclusive remedy under this warranty, the manufacturer, at its option, may repair or replace the non-conforming product or issue credit, provided the manufacturer's inspection establishes the existence of a defect. To exercise this remedy, the buyer must contact the manufacturer's Customer Service Department to obtain a Return Material Authorization number and shipping instructions. Products returned without prior authorization will be returned to buyer. All products returned for repair must be shipped freight prepaid to UNIPOWER. If the buyer fails to fully comply with the foregoing, the buyer agrees that no other remedy (including, but not limited to, incidental or consequential damages for lost profits, lost sales, injury to person or property or any other incidental or consequential losses) shall be available to the buyer.

10.0 UNPACKING AND INSPECTION

- 10.1 This Gravitas X150 Integrated DC Power System was carefully tested, inspected and packaged for shipment from our factory. Upon receipt of the unit it should be carefully unpacked and inspected for any damage in shipment.
- 10.2 If there is evidence of damage, do not attempt to install the unit. The freight carrier should be notified immediately and a claim for the cost of the system should be filed with the carrier for direct reimbursement. Be sure to include the model and serial number of the damaged unit in all correspondence with the freight carrier. Also save the shipping carton and packing material as evidence of damage for the freight carrier's inspection.
- 10.3 UNIPOWER Telecom will cooperate fully in case of any shipping damage investigation.
- 10.4 Always save the packing materials for later use in shipping the unit. Never ship the rectifier system without proper packing.

11.0 DESCRIPTION OF OPERATION

- 11.1 **Block Diagram.** A simplified block diagram of the Gravitas X150 is shown in Figure 6.
- 11.2 **Operation.** The AC input of 120 or 230VAC goes to all three rectifier modules. The input of each module has power factor correction resulting in a power factor near unity. The outputs of the three modules are connected in parallel with an ORing diode on the output of each rectifier. This allows each rectifier module to be hot-swapped without disturbing the output voltage.

The -48 or +24VDC output goes through the LVD contactor and the battery circuit breaker to the battery. The output also goes to the load circuit breakers and then to each load. If the rectifier bus voltage drops below 42.5VDC for a -48 system or 21.25VDC for a +24V system, the LVD contactor opens and disconnects the battery from the system output. This generally happens when there is a failure in the AC input to the rectifiers. When AC input is restored and the rectifier bus voltage rises above 49.0VDC for a -48V system or 24.5VDC for a +24V system, the LVD contactor closes again.

- 11.3 Control and Monitoring.** The analog controller has inputs from and outputs to each rectifier module. The inputs let the controller monitor the operation of each rectifier module and detect failure if it occurs. The outputs to the rectifier modules let the controller control the module output voltage. Likewise, there is an input and output from the Low Voltage Disconnect (LVD), an input from the battery and an input from each load breaker. These signals result in operation of the alarm LEDs and the Form C relay alarms. The controller also has digital meters to read the load voltage and current. A 50mV shunt is located in the rectifier bus to measure the load current. The digital controller operates in the same way except that it is digitally programmed from a keypad.

12.0 INSTALLATION

- 12.1 CAUTION: Re-read the Safety Warnings and Precautions in Section 8.0. All power should be OFF for the input and output loads before making connections. Connection of the X150 chassis to frame ground should be made first. If the X150 has been turned on before installation connections, it should be turned off and given a 5-minute waiting period for all internal energy storage capacitors to be discharged.**
- 12.2 Input AC Power Connection.** See Figure 7. An unplugged 3-wire AC power line should be connected into the slots of the DIN-Rail terminal blocks. The terminal block screws just above the connection slots should be firmly screwed against the AC input cables to eliminate any contact resistance. The line, neutral and ground connections should be carefully followed when making the AC connections. The AC line cable should be sized to safely carry 22 amperes AC.
- 12.3 Checking Outputs.** Turn all output circuit breakers to the OFF position and/or remove all fuses from the GMT fuse-holder. With no loads connected and without the battery connected, plug in or connect the AC input cable to the power source. Be sure to use the correct AC voltage for the rectifier inputs. Observe the DC voltage reading on the digital voltmeter on the controller panel or at the test points. The voltage should be approximately 54.4 or 27.2 (depending on model) VDC, which is the factory setting. The digital ammeter or test points should read zero. One by one, turn each output circuit breaker to the ON position and/or insert a GMT fuse and, using a digital voltmeter, measure the DC voltage across the corresponding output terminals. The voltage should again read approximately 54.4 or 27.2 volts. After each output is measured, turn OFF that circuit breaker and/or remove the GMT fuse and turn ON and/or insert fuse in the next one. After measuring the last circuit, turn off that breaker and/or remove the GMT fuse and make sure that all output breakers are in the OFF position and/or all

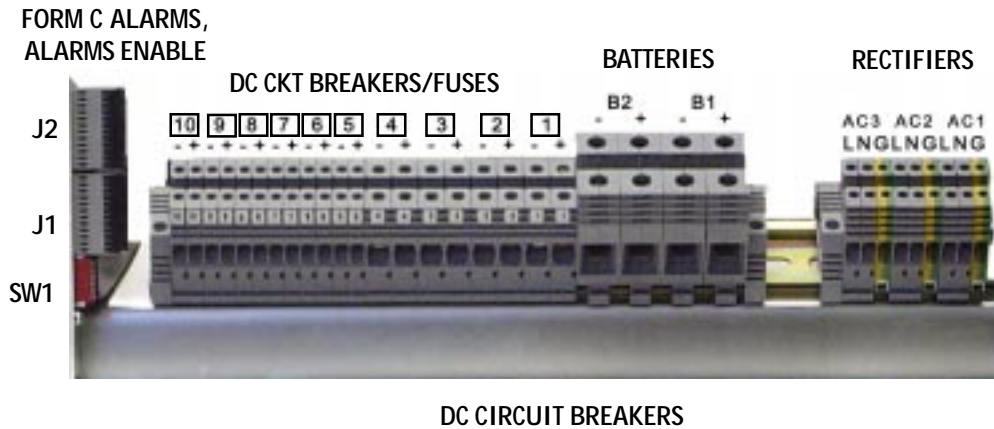

Figure 7. Gravitas X150 Connection Terminals

INTERFACE CONNECTIONS

PIN	SIGNAL
12	RFA (minor)-NC (Rectifier fail, minor)
11	RFA (minor)-C (Rectifier fail, minor)
10	RFA (minor)-NO (Rectifier fail, minor)
9	RFA (major)-NC (Rectifier fail, major)
8	RFA (major)-C (Rectifier fail, major)
7	RFA (major)-NO (Rectifier fail, major)
6	OVA-NC (Overvoltage alarm)
5	OVA-C (Overvoltage alarm)
4	OVA-NO (Overvoltage alarm)
3	UVA-NC (Undervoltage alarm)
2	UVA-C (Undervoltage alarm)
1	UVA-NO (Undervoltage alarm)

PIN	SIGNAL
12	TC+ (Temp. Comp.)
11	TC- (Temp. Comp.)
10	No Connection
9	LVDA-NC (Low voltage disconnect alarm)
8	LVDA-C (Low voltage disconnect alarm)
7	LVDA-NO (Low voltage disconnect alarm)
6	ACFA-NC (AC fail alarm)
5	ACFA-C (AC fail alarm)
4	ACFA-NO (AC fail alarm)
3	FA-NC (Circuit breaker alarm)
2	FA-C (Circuit breaker alarm)
1	FA-NO (Circuit breaker alarm)

ALARM ENABLE SWITCH

POSITION	FUNCTION
1	ON - Enable Rect 1
2	ON - Enable Rect 2
3	ON - Enable Rect 3
4	No Connection
5	No Connection
6	ON - Enable LVD

Figure 8. Gravitas X150 Signal Interface Connections

fuses are removed. Next, unplug or disconnect the AC input power source. Before touching any terminals wait 5 minutes for the internal storage capacitors to discharge.

- 12.4 Controller Section Operation and Settings.** At this point, before the final installation connections, read sections 13 through 21, covering the Analog Control Panel operation. Next, go back to sections 19, 20 and 21 and make the signal connections, controller adjustments, temperature compensation adjustment and alarm enabling settings. For operating information on the digital controller, please contact the factory.

WARNING: Remember to take precautions each time the system is turned on and also when connecting or disconnecting the battery. Remember that the battery has a hazardous voltage at its terminals. Also remember to allow 5 minutes for internal capacitors to discharge after disconnecting the AC input power and the battery.

- 12.5 Connection to Loads.** With input AC power unplugged, the battery disconnected and no other power sources connected to the loads, make sure that all load circuit breakers are set to the OFF position and/or all GMT fuses are removed.

See Figures 3 and 7. Connect load wires to each set of output terminals, one at a time. Note that the front panel breaker and fuse numbers directly correspond to the output terminal numbers. Be sure to connect the polarities correctly as shown in Figure 7.

- 12.6 Connection to Battery.** With AC input unplugged, remove the three rectifier modules from the system chassis. Make sure all load circuit breakers are in the OFF position and/or all GMT fuses removed. Set the battery circuit breaker to the OFF position. Carefully connect the battery cables to the DIN-Rail battery terminals shown in Figure 7 while observing the correct polarity.

WARNING: Improper polarity of the battery connection may damage the power system. Take precautions when installing the battery and note that the battery cables are “hot” (live).

Set the battery circuit breaker to the ON position and observe the reading on the digital voltmeter on the controller panel or connected to the test points. It should indicate the voltage of the battery, approximately 48 or 24VDC when charged. If the battery is connected with wrong polarity, there will be no reading on the digital voltmeter.

12.7 System Turn-On. Perform the following operations:

- ◆ Put the battery circuit breaker in the OFF position
- ◆ Plug in the three rectifier modules
- ◆ Connect the AC power cable to the AC source
- ◆ Put the battery circuit breaker in the ON position
- ◆ Check the digital voltmeter reading for the correct voltage
- ◆ Set each load circuit breaker to the ON position and/or insert each fuse
- ◆ Note the reading on the digital ammeter (controller panel or test points).

With all loads connected, the output current should not exceed 75 amperes for non-redundant operation (50 amperes for 2 + 1 redundant operation) for the -48V, 75 ampere models or 150 amperes for non-redundant operation (100 amperes for 2+1 redundant operation) for the -48V and +24V, 150 ampere models.

13.0 INTRODUCTION TO CONTROL & MONITORING

13.1 The analog controller is a basic control and monitoring system for the X150 power system. It controls up to 3 rectifiers, precisely setting the float voltage on all rectifiers simultaneously. It monitors the battery voltage and current by means of front panel test points or by the optional front panel digital voltmeter and ammeter. See Figure 5.

13.2 Front panel LEDs indicate status and alarm conditions of the monitored functions. Front panel potentiometers permit easy adjustment of the various control voltages. Form C relays also indicate status and alarms.

13.3 For instructions on using the optional digital controller, please contact the factory.

14.0 ANALOG CONTROLLER FRONT PANEL DESCRIPTION

14.1 On the left side of the front panel are the optional digital voltmeter and digital ammeter. These meters read battery voltage and load current; the voltage and current test points read the same voltage and current. The ammeter and current test points use an internal 50mV shunt. See Figure 5.

14.2 At the center of the panel is a green/red LED alarm which is normally green but turns red upon failure of the Control and Monitor System.

14.3 On the right side are the four terminals for reading amperes and volts, the load current and voltage, using external meters.

- 14.4 Next, in order, are the voltage adjustment potentiometers VFL, OV, UV, and TC. See the definitions in section 17.0.
- 14.5 Finally, in order, are the LED indicators: RFA-MIN, RFA-MAJ, ACFA, FA, LVDA, OVA and UVA. See the definitions in section 16.0.

15.0 SIGNAL INPUT/OUTPUT CONNECTIONS

See Figure 8 for location and description of input and output signals, including the alarm enable switches. The input and output signal connections are to spring-clamp terminal blocks.

16.0 ANALOG CONTROLLER LED INDICATORS

Red LEDs. These are failure alarms indicating the following:

- ◆ **RFA-MIN:** Rectifier Failure Alarm-Minor (a single rectifier failure)
- ◆ **RFA-MAJ:** Rectifier Failure Alarm -Major (two or more rectifier failures)
- ◆ **ACFA:** AC Input Failure (on any rectifier)
- ◆ **FA:** Failure on any circuit breaker or fuse in the distribution panel
- ◆ **LVDA:** Low Voltage Disconnect
- ◆ **OVA:** Battery Overvoltage
- ◆ **UVA:** Battery Undervoltage

17.0 FRONT PANEL ADJUSTMENT POTENTIOMETERS

There are four front panel adjustment potentiometers:

- ◆ **VFL:** Float Voltage set (12 turns)
- ◆ **OV:** Battery Overvoltage set (single turn)
- ◆ **UV:** Battery Undervoltage set (single turn)
- ◆ **TC:** Temperature Compensation set (single turn)

Note that Temperature Compensation is an option.

18.0 DESCRIPTION OF ANALOG CONTROLLER OPERATION

- 18.1 The system controls and monitors up to three rectifier modules. This is accomplished by means of a control cable which connects between the rectifier section and controller. Through these connections the controller controls the rectifier

output voltage which is preset by the VFL (float voltage) adjustment potentiometer.

- 18.2** The Controller also monitors the AC input and DC output of each of the rectifiers and gives an LED warning and Form C relay contact alarm in case of failure of any one or more of the rectifier modules.
- 18.3** The Controller also monitors for alarms from the low voltage disconnect and circuit breaker panel. The alarm outputs are Form C relay contacts which can be used for remote or local system alarms.
- 18.4** Other alarm outputs are for battery overvoltage and battery undervoltage. These are also Form C relay contacts.
- 18.5** Battery voltage and current are also monitored by the controller. They are read either by the optional front panel voltmeter and ammeter or from the front panel test points. When using the front panel test points with an external voltmeter, the system output voltage is read directly from the voltage test points. The current, however, is read as the voltage across the current test points which go to a 50mV shunt. A 50mV shunt voltage corresponds to 150 amperes which is the full scale current. This results in a voltage scale factor of 3 amperes per millivolt.
- 18.6** The controller initiates a Form C alarm when any one or more circuit breakers have tripped or GMT fuses have blown.

19.0 CONTROLLER SIGNAL CONNECTIONS

- 19.1** See Figure 8. Signal connections to the J1 and J2 spring-clamp terminal blocks should to be made with wire gauges no. 20-26 AWG. Insulation should be stripped 0.2" from wire end.

Alarm signals are Form C relay contact alarms for the function given. "Normally Closed" (NC) means a "short" between this terminal and the Common (C) terminal when the function is operating properly with power applied. "Normally Open" (NO) means an "open" between this terminal and the Common (C) terminal when the function is operating properly with power applied.

19.2 Abbreviations/Acronyms.

ACRONYM	DESCRIPTION
LVDA	Low Voltage Disconnect Alarm
FA	Fuse or Circuit Breaker Alarm
TC	Temperature Compensation (from probe)
OVA	Battery Overvoltage Alarm
RFA-MIN	Rectifier Failure Alarm - Minor (single rectifier failure)
ACFA	AC Failure Alarm
RFA-MAJ	Rectifier Failure Alarm - Major (two or more rectifier failures)
UVA	Battery Undervoltage Alarm

19.3 Alarm and Signal Setup.

19.31 General. All signals are preset at the factory, and these values are listed in the following sections. Where voltages are given, the first one is for a -48VDC system and the second, for a +24V system.

19.32 LVD Dropout and Pickup. The Low-Voltage Disconnect (LVD) is an option. The trip levels are factory set at -42.5 or +21.25VDC dropout and -49.0 or +24.5VDC pickup. These are not field adjustable.

19.33 Battery Float Voltage. The voltage is set at the factory at -54.4 or +27.2VDC. If a different nominal value is required, do the following:

- ◆ Install all rectifiers in the system.
- ◆ Disconnect the battery and adjust the float voltage (VFL) potentiometer on front panel to the level required. **Do not use the voltage adjustments on the front panel of the rectifier modules.**
- ◆ Reconnect the battery.

19.34 Battery Overvoltage. The voltage across the battery where the overvoltage alarm trips is factory set at -57.0 or +28.5VDC. If a different nominal value is required, do the following:

- ◆ Unplug all rectifiers, disconnect AC, disconnect all loads and the battery.
- ◆ With an external variable voltage supply rated 0-60VDC, connect it across one set of the output load terminals and turn on its associated circuit breaker on the front panel. Be sure to observe the correct polarity.
- ◆ Bring the voltage up to approximately -55V or +27.5V.
- ◆ Verify that alarm LED (OVA) is off.

- ◆ Verify that the alarm LED goes on when the voltage is adjusted to -57VDC ± 0.5VDC or +28.5VDC ± 0.25VDC.
- ◆ Readjust the 0V potentiometer on the front panel to set at the desired level.
- ◆ Verify that the alarm LED goes red at the set point.

19.35 Battery Undervoltage. The voltage across the battery where the undervoltage alarm trips is factory set at -44.0VDC or +22.0VDC. If a different value is required, do the following:

- ◆ Follow the same procedure as described above for overvoltage alarm setup.
- ◆ At -55V or +27.5V verify the alarm LED (UVA) is off.
- ◆ It should turn red when the voltage is adjusted to -44.0VDC ± 0.5VDC or +22VDC ± 0.25VDC.
- ◆ Readjust the UV potentiometer on the front panel to set at the desired level.
- ◆ Verify that the alarm LED goes red at the set point.

19.36 TC Input. This is the optional temperature compensation input from the temperature compensation probe that comes with this option. The probe is used to measure battery temperature which is used to control the output of the rectifier. There is no polarity reference for connecting the temperature probe. Connection of the probe is to pins 11 and 12 of J1. See Figure 8. See Section 20 for further details on temperature compensation.

20.0 BATTERY TEMPERATURE COMPENSATION (OPTION)

20.1 The temperature compensation option comes with a temperature probe and 20-foot cable. The probe is a thermistor which is connected to J1 pins 11 and 12. There is no polarity for this connection. The probe is used to monitor the temperature of the battery and adjust the rectifier output voltage accordingly. As battery temperature increases, rectifier output voltage decreases.

20.2 The change in output voltage with temperature is -3mV/°C per battery cell, centered at 25°C. For example, for a +10°C temperature change from 25°C with the rectifier charging a 48V battery, the change in the rectifier output voltage would be:

$$\frac{48}{2} = 24 \text{ cells}$$

$$\Delta V = 24 \text{ cells} \times 10^\circ\text{C change} \times (-3\text{mV}) = -720\text{mV} = -0.72\text{V}$$

- 20.3 The probe can be located in several possible places: right on the battery to detect the battery temperature, near the battery in free air to detect the local ambient temperature, or on the power plant metal frame near the battery.
- 20.4 If the TC probe is either opened or shorted, the rectifier outputs revert to the float voltage.
- 20.5 **Setting the Temperature Compensation Voltage.**
- 20.51 Make sure that the float voltage was set with the temperature probe disconnected.
- 20.52 Before connecting the temperature probe, record the float voltage to three digits.
- 20.53 Connect the temperature probe to terminals 11 and 12 of J1.
- 20.54 With the temperature probe at approximately 25°C ambient temperature, adjust the front panel TC potentiometer until the rectifier output voltage as read on the front panel voltmeter or external voltmeter is exactly the same as the previously recorded float voltage.

21.0 ALARM ENABLING

- 21.1 **Alarm-Enable Switches.** These switches are located on the back, left side of the system shelf and are shown in Fig. 8. A switch moved to the **right** position, or “on”, enables its associated alarm. A switch moved to the **left** position, or “open”, disables the alarm.
- 21.2 There are four alarm functions that require enable:
- ◆ LVD Alarm
 - ◆ Rectifier #1 - ACFA and RFA
 - ◆ Rectifier #2 - ACFA and RFA
 - ◆ Rectifier #3 - ACFA and RFA
- 21.3 If the LVD option is present, SW1 switch position 6 should be “on” for enable. When all rectifier slots are used SW1 switch positions 1, 2, 3 should be switched to “on”. If any rectifier slot is not used in the end application and/or if the LVD option is not present, the corresponding slot alarms should be disabled by switching the corresponding SW1 switch positions to “open”.

- 21.4 After making the signal connections, controller adjustments, temperature compensation adjustment and alarm enable settings of Sections 19 through 21, go back to Section 12.5 to continue the installation procedure.

22.0 VOLTAGE AND CURRENT MEASUREMENTS

- 22.1 **Meters and Test Points.** The control panel provides an optional digital voltmeter and ammeter on the left front panel to monitor the battery voltage and load current.
- 22.2 **Voltage.** The digital voltmeter reads battery voltage directly, to tenths of a volt. The "VOLTS" test points on the right front panel also permit direct external measurement of the battery voltage.
- 22.3 **Current.** The digital ammeter is scaled at the factory to read amperes based on a 50 millivolt internal shunt. The "AMPS" test points permit direct external measurement of the load current. A voltmeter across these test points gives a reading of 3 amperes per millivolt.

23.0 MAINTENANCE

No routine maintenance is required on the Gravitas X150 power system except for periodic cleaning of dust and dirt around the rectifier module fans and ventilation holes. A small vacuum nozzle should be used for this.

COMPACT INTEGRATED DC POWER SYSTEM

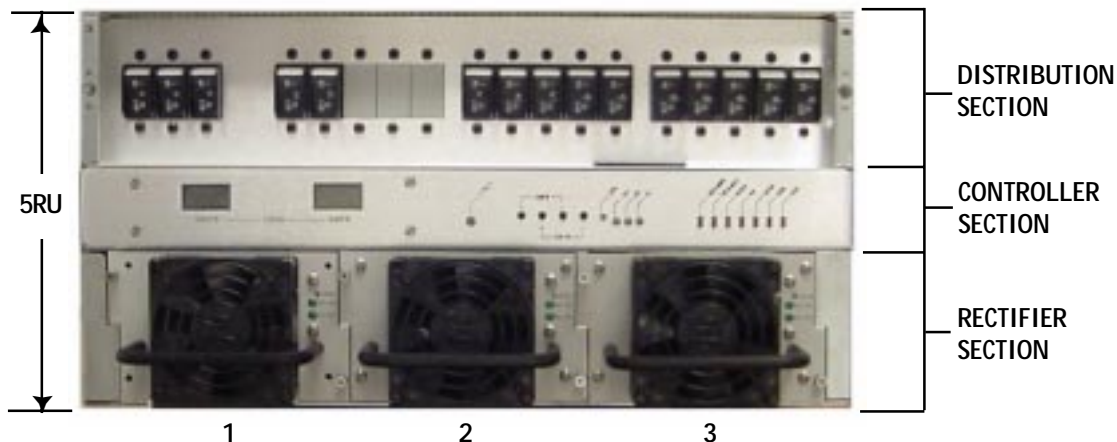

DESCRIPTION

KEY FEATURES

- ◆ Compact, 5RU High
- ◆ Fully Integrated System
- ◆ Flexible Configuration
- ◆ Hot-Swap Rectifier Modules
- ◆ -48 or +24VDC, Up to 150A
- ◆ Easy Installation

Gravitas X150 is a compact, integrated, DC power system. It consists of up to three high power-density, hot-swap rectifier modules which can produce 75 amperes at -48VDC, 150 amperes at -48VDC or 150 amperes at +24VDC, depending on system configuration. In a 2+1 redundant operation the output currents are 50, 100 and 100 amperes, respectively.

The system has a DC distribution panel with up to 10 load circuits which are protected by circuit breakers, GMT fuses or a combination of the two. Three AC breakers are optional, with one breaker for each rectifier input. Also optional is a low-voltage battery disconnect. Battery breakers for up to three battery strings can be provided.

There are two choices for the system controller. A standard analog controller has LED visual alarms, Form C relay alarms, test points and set-point adjustments including over- and under-voltage adjustments. There is a temperature compensation option and digital voltage and current display option. An optional digital controller provides all these features in keyboard format with an alphanumeric display and remote data access options.

The complete Gravitas X150 is only 5RU high (8.65 inches or 220mm) and is easily installed by a qualified technician. All connections are at the rear to DIN-rail terminal blocks. A comprehensive operating manual explains all the details of operation and installation. The units may be mounted in 19- or 23-inch racks.

TWO-YEAR WARRANTY



GRAVITAS X150 SUMMARY FEATURES

- | | |
|--|--|
| <ul style="list-style-type: none"> ◆ Choice of Hot-Swap Rectifiers ◆ 120 or 230VAC Input ◆ Power Factor Corrected ◆ AC Line Breakers Option ◆ Class B EMI Input Filter ◆ Up to 150A at -48 or +24VDC ◆ Up to 100A for 2+1 Redundant ◆ Up to 10 DC Circuit Breakers or Fuses ◆ Up to 3 Battery Strings | <ul style="list-style-type: none"> ◆ Up to 3 Battery String Breakers ◆ LV Battery Disconnect Option ◆ Analog or Digital Controller ◆ Communication Options ◆ Distribution Section Cover ◆ Distribution Section Wallet ◆ Quick, Easy Installation ◆ Modular Design ◆ Only 5RU (8.65 Inches) High |
|--|--|

SYSTEM MODEL NO.

SYSTEM CAPABILITY	X150-48R/150	X150-48R/75	X150-48M/75	X150-24R/150	X150-24M/150
System Voltage	-48VDC	-48VDC	-48VDC	+24VDC	+24VDC
System Max. Current	150A	75A	75A	150A	150A
System Current, 2+1	100A	50A	50A	100A	100A
Input Range, VAC	170-264	85-264	170-264	85-264	170-264
Rectifier Model	RRS48/50	RRP48/25	RMP48/25	RRP24/50	RMP24/50
Rectifiers Required	3	3	3	3	3
Input Breakers, AC ¹	3 optional	3 optional	3 optional	3 optional	3 optional
Battery String Breakers	2 standard	1 standard	1 standard	2 standard	2 standard
Extra Breaker	1 optional	1 optional	1 optional	1 optional	1 optional
LVD, 150 Amp ²	optional	optional	optional	optional	optional
Total No. of DC Loads ³	10	10	10	10	10
25-50A Breakers	4	4	4	4	4
1-20A Breakers	10	10	10	10	10
½-12A GMT Fuses	10	10	10	10	10
Control Features					
Alarm Outputs	7 standard	7 standard	7 standard	7 standard	7 standard
Temp. Compensation	optional	optional	optional	optional	optional
Communications					
LAN	optional	optional	optional	optional	optional
Modem	optional	optional	optional	optional	optional
Local RS232	optional	optional	optional	optional	optional
Rack Height	5RU	5RU	5RU	5RU	5RU
Rack Width, Inches ⁴	19	19	19	19	19

- NOTES: 1. One per rectifier module.
 2. Battery disconnect.
 3. May total 12 if no battery string breakers are used. Check with factory.
 4. 23-Inch mounting brackets can be supplied.



X150 SYSTEM WITH COVER

RECTIFIER MODULES

MODULE MODEL NO.					
SPECIFICATIONS	RRS48/50	RRP48/25	RMP48/25	RRP24/50	RMP24/50
Output Voltage, Nom.	48VDC	48VDC	48VDC	24VDC	24VDC
Output Voltage, Set	54.4V	54.4V	54.4V	27.2V	27.2V
Output Voltage Range	45-58V	45-58V	45-58V	22.5-29V	22.5-29V
Output Current, Max.	50A	25A	25A	50A	50A
Output Watts, Max.	2,720	1,360	1,360	1,360	1,360
Input Range, VAC	170-264	85-264	170-264	85-264	170-264
Input Power Factor	0.98	0.98	0.99	0.98	0.99
Input Current, 230VAC	14.2A	7.1A	7.1A	7.1A	7.1A
120VAC	-	13.6A	-	13.6A	-
Inrush Current Limit	25A Pk.	25A Pk.	50A Pk.	25A Pk.	50A Pk.
Input Frequency, Hz	47-63	47-63	47-63	47-63	47-63
Efficiency	87%	87%	87%	85%	85%
Total Regulation, Max.	1.0%	1.0%	1.0%	1.0%	1.0%

RECTIFIER MODULE SPECIFICATIONS

INPUT

Voltage Range _____ 85-264 or 170-264VAC
 Power Factor _____ 0.98 or 0.99
 Total Harmonic Distortion, Max. _____ 5%
 Frequency _____ 47-63Hz
 Inrush Current Limiting _____ 25 or 50A Peak
 EMI Filter, Conducted _____ FCC20780 pt. 15J Curve B
 _____ EN55022 Curve B
 Input Immunity, Conducted
 Fast Transients, Line-Line $\pm 2kV$ (EN61000-4-4 Level 3)
 Surges, Line-Line _____ $\pm 1kV$ (EN61000-4-5 Level 2)
 Surges, Line-Ground _____ $\pm 2kV$ (EN61000-4-5 Level 3)

OUTPUT

Output Voltage Set, 48V Nom. _____ 54.4VDC
 24V Nom. _____ 27.2VDC
 Voltage Adjustment Range, 48V Nom. _____ 45-58VDC
 24V Nom. _____ 22.5-29VDC
 Total Regulation, Max. _____ 1.0%
 Holdup Time _____ 20msec.
 Overvoltage Protection, 48V Out _____ 59V
 24V Out _____ 29V

Filtering: Wideband Noise, 20Mhz BW
 48V Out, P-P _____ 500mV
 24V Out, P-P _____ 250mV
 Voice Band Noise _____ <32dBmC
 Current Limit _____ 105% Rated Current
 Efficiency _____ 85-87%

STATUS INDICATORS

AC Good _____ Green LED
 DC Good _____ Green LED

ENVIRONMENTAL

Operating Temp. Range _____ 0°C to +70°C
 Output Current Derating _____ 2.5%/°C, 50°C to 70°C
 Storage Temp. Range _____ -40°C to + 85°C
 Humidity _____ 0% to 95%, Non-Condensing
 ESD _____ Bellcore GR-1089-Core and EN61000-4-2
 Cooling _____ Internal Fans

ANALOG CONTROLLER (Standard)

This basic controller controls the system rectifier, monitors the system parameters and has alarms for system failures. There are seven red LED alarms which also have Form C relay outputs to indicate a failure: Rectifier-Major, Rectifier-Minor, AC Input, Fuse or Circuit Breaker, Low Voltage Disconnect, Overvoltage and Undervoltage. Four front-panel voltage-set adjustments are for Float Voltage, Battery Overvoltage, Battery Undervoltage and Temperature Compensation. Test points for load voltage and current permit external measurement of these values. Options for this controller include digital meters for continuously monitoring battery voltage and load current and a temperature probe which provides a temperature compensated output from the rectifier.

DIGITAL CONTROLLER (Option)

This full-featured controller is a control and supervisory unit that communicates directly with the rectifier to monitor and control its function. The digital controller features a keypad and a backlit 2x24 character alphanumeric display. All system parameters can be controlled by the keypad. Alternatively, the system can be controlled by software from a remote PC by means of a standard RS232 port or via an optional modem or Ethernet LAN. This controller also has an optional temperature probe for temperature compensated output from the rectifier.

DISTRIBUTION SECTION

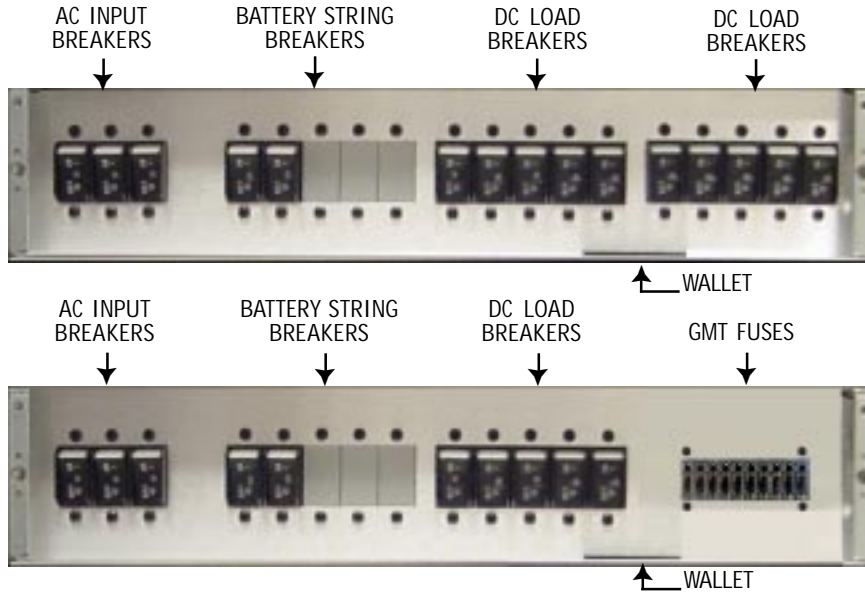

CONTROLLER SECTION
ANALOG CONTROLLER

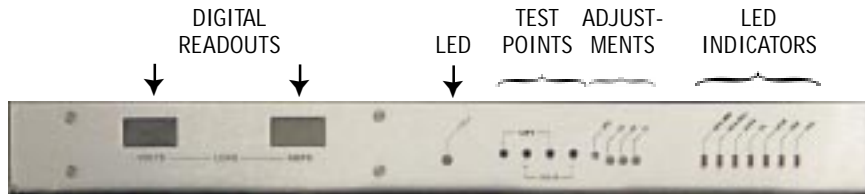

DIGITAL CONTROLLER



REAR VIEW

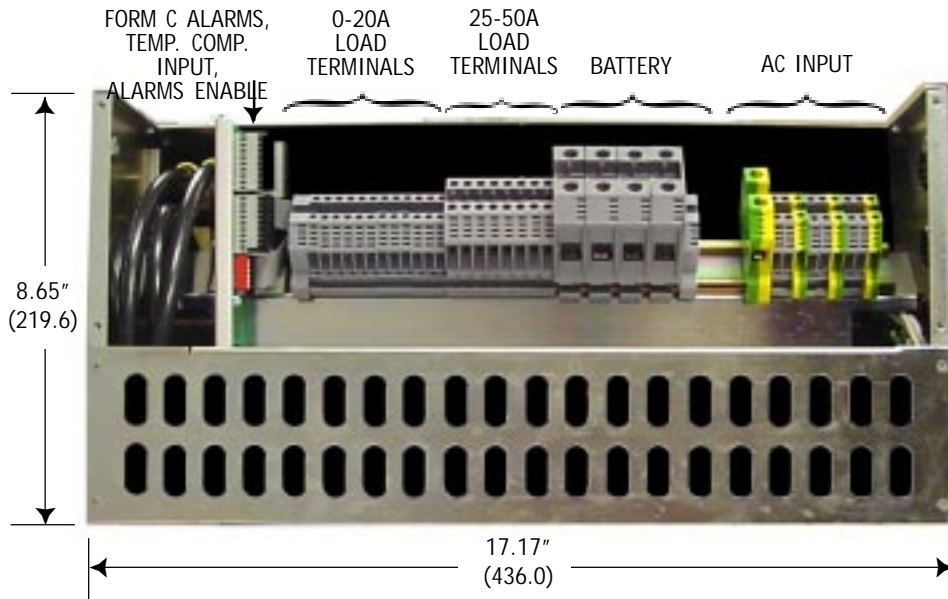

DEPTH IS:
15.90"
(403.8)
inches (mm)

CONFIGURATION GUIDE

SYSTEM MODEL NO.	SYSTEM OUTPUT, MAX.	INPUT, VAC	RECTIFIER MODULES	NO. MODULES ORDERED			
<input type="checkbox"/> X150-48R/150	-48VDC@150A	170-264VAC	RRS48/50	_____			
<input type="checkbox"/> X150-48R/75	-48VDC@75A	85-264VAC	RRP48/25	_____			
<input type="checkbox"/> X150-48M/75	-48VDC@75A	170-264VAC	RMP48/25	_____			
<input type="checkbox"/> X150-24R/150	+24VDC@150A	85-264VAC	RRP24/50	_____			
<input type="checkbox"/> X150-24M/150	+24VDC@150A	170-264VAC	RMP24/50	_____			
Check the System Model No. desired and indicate the number of Rectifier Modules ordered, including spares. Maximum number of operating rectifier modules per system is three.							
INPUT PROTECTION (OPTION)							
<input type="checkbox"/> Circuit Breakers (1 per Rectifier)							
BATTERY PROTECTION							
<input type="checkbox"/> 1 Battery String Breaker (Standard for 75A Output)							
<input type="checkbox"/> 2 Battery String Breakers (standard for 150A Output)							
<input type="checkbox"/> 1 Extra Battery String Breaker (Option)							
<input type="checkbox"/> Low-Voltage Battery Disconnect (Option)							
DC DISTRIBUTION (OPTIONS)							
<input type="checkbox"/> OPTION A: Up to 10 Breakers Total							
1. Breaker ___ A (1-50A) 5. Breaker ___ A (1-20A) 9. Breaker ___ A (1-20A)							
2. Breaker ___ A (1-50A) 6. Breaker ___ A (1-20A) 10. Breaker ___ A (1-20A)							
3. Breaker ___ A (1-50A) 7. Breaker ___ A (1-20A)							
4. Breaker ___ A (1-50A) 8. Breaker ___ A (1-20A)							
<input type="checkbox"/> OPTION B: Up to 10 GMT Fuses & Up to 4 Breakers (Total of 10 Max.)							
1. 10-Position GMT Fuse Block (Standard, 80A Max.)							
2. Breaker ___ A (1-50A) 4. Breaker ___ A (1-50A)							
3. Breaker ___ A (1-50A) 5. Breaker ___ A (1-50A)							
BREAKERS & FUSES AVAILABLE							
Breakers: 1, 2.5, 5, 10, 15, 20, 25, 30, 40, & 50A (Enter in Option A or B)							
GMT Fuses: Order the number required. Maximum total current is 80A.							
AMPS	BUSSMAN NO.	COLOR	NO. REQ'D	AMPS	BUSSMAN NO.	COLOR	NO. REQ'D
0.5A	GMT- 1/2	Red		3	GMT- 3	Blue	
0.75	GMT- 3/4	Brown		5	GMT- 5	Green	
1	GMT - 1	Gray		10	GMT - 10	Red-White	
1.33	GMT-1 1/3	White		12	GMT- 12	Green-Yel	
2	GMT-2	Orange		0	GMT-Dummy	Orange	
CONTROLLER & OPTIONS							
<input type="checkbox"/> Basic Analog Controller (Standard)							
<input type="checkbox"/> Temperature Compensation (Option)							
<input type="checkbox"/> Digital Voltage & Current Displays (Option)							
<input type="checkbox"/> Digital Controller with Keyboard, Display and RS232 (Option)							
<input type="checkbox"/> Remote Access Modem (Option)							
<input type="checkbox"/> Remote Access Ethernet, LAN (Option)							
<input type="checkbox"/> Temperature Compensation (Option)							
BLANK COVERS (FOR UNUSED RECTIFIER SLOTS)							
Cover Position: <input type="checkbox"/> 1 <input type="checkbox"/> 2 <input type="checkbox"/> 3 (left to right)							
MOUNTING BRACKETS							
<input type="checkbox"/> 19-Inch <input type="checkbox"/> 23-Inch							

THREE-PHASE POWER WITH UNIPOWER FRONT-ENDS AND RECTIFIERS

1.0 Introduction. This application note discusses three-phase power and the operation of UNIPOWER front-ends and UNIPOWER Telecom rectifiers. Three-phase AC input power can be useful with high-power front ends and rectifiers in the several thousand watt area of power. This applies to many of UNIPOWER's power and rectifier modules that use the model RRS2U-19 three-unit rack/shelf (see Figure 1) and also the Gravitas Compact, Integrated DC Power Systems.

The three-module bulk power front ends and telecom rectifiers are readily adaptable to balanced three-phase power operation since there are separate, isolated AC inputs to each of the three modules.

2.0 Three-Phase Power. As a brief review, three-phase power may be represented by the phasor diagram of Figure 2. This diagram represents a 120/208 VAC North American three-phase power source. Each phase, A, B, and C, is 120 VAC in magnitude (to neutral) and each is separated from the other by a 120° phase angle. The phase relationship of the three voltages makes them sum to zero at all times. By trigonometry, the phase-to-phase voltage has a magnitude of $120 \times \sqrt{3}$ VAC or 208 VAC. The three phase-to-phase voltages also sum to zero at all times. Connections can be made either from phase to phase (208 VAC), which is called a delta (Δ) connection, or phase to neutral (120 VAC), which is called a wye (\tilde{O}) connection.

The phasor diagram of Figure 3 represents a European (U.K.) three-phase power source with a 240 VAC phasor magnitude and a $240 \times \sqrt{3}$ or 415 VAC phase-to-phase voltage. This is the United Kingdom standard whereas the standard for most other nations of Europe is 220/380VAC.

3.0 Connections for UNIPOWER Products. The following table lists the output power, input voltage range and correct three-phase connection for each of the pertinent UNIPOWER products.



TABLE 3.1 Three-Phase Connection of Unipower Products

UNIPOWER SERIES	TOTAL POWER (W)	INPUT VAC RANGE	NORTH AMER. CONNECTION	EUROPE CONNECTION
TMP	3,600	170-264	Ä	Ö
TRP	3,744	85-264	Ö or Ä	Ö
TRR	6,005	170-264	Ä	Ö
TRS	7,502	170-264	Ä	Ö
Meridan RMP	4,080	170-264	Ä	Ö
Ranger RRP	4,080	85-264	Ö or Ä	Ö
Ranger RRS	8,160	170-264	Ä	Ö
Gravitas X150/300				
RMP Modules	4,080	170-264	Ä	Ö
RRP Modules	4,080	85-264	Ö or Ä	Ö
RRS Modules	8,160	170-264	Ä	Ö

The rule is that for North America a unit with 170-264 VAC input must be connected only in the 208 VAC delta configuration; for 85-264 VAC input, the unit can be connected in either the 120 VAC wye or 208 VAC delta configuration.

For Europe, both input voltage ranges must be connected only in the 220 or 240 VAC wye configuration. The 380 or 415 VAC delta connection exceeds the input voltage range of the units.

4.0 AC Input Connections. Figure 4 shows the AC input terminal block for the RRS2U-19 three-unit rack which is the common rack/shelf for all the power/rectifier modules in the table, not including the Gravitas systems. AC input connections for the Gravitas X150 and X300 Compact, Integrated DC Power Systems are shown in Figure 5. In both cases the neutral (N) terminal is actually a neutral/line (N/L) terminal since it is isolated from the ground connection.

5.0 Three-Phase Delta Connection. Figure 6 shows the connection to three power or rectifier modules with 170-264 VAC input range to the North America three-phase 208 VAC delta source. The delta connection is from phase to phase with phases labeled A, B and C. For proper protection, two-pole circuit breakers are used at each module input as shown in the diagram. The source neutral connection is not used. It should be noted that the total current drawn from each phase is $\sqrt{3}$ times the input current for one module.

Note that the delta connection must not be used for a European three-phase power source since the voltage is 380 or 415 VAC, exceeding the maximum power or rectifier module input voltage of 264 VAC.

6.0 Three-Phase Wye Connection. Figure 7 shows the wye connection to three power or rectifier modules with 85-264 VAC input range. Each module is connected from one of the phases A, B or C to neutral. This is the connection that may be used to North American three-phase sources. It is also the connection that must be used for European 240/415 VAC three-phase sources for both 85-264 VAC and 170-264 VAC input ranges.

Here, a single-pole circuit breaker is used for each module, on the line side of each input, since the other side is neutral. For a fully loaded RRS rectifier module or TRS power module on North American three-phase power, the circuit breaker should be at least 20 amperes. For a European wye connection, the circuit breaker should be 20 amperes minimum for a fully loaded RRS or TRS module. Input current (RRS) as mentioned previously is approximately 19.2 amperes at 170 VAC.

7.0 Additional Comments. In either of the two three-phase connections, 2+1 redundancy may be used. This means that two of the three modules must be able to carry the full load. If one of the modules fails and trips its breaker, the other two will continue to function from the three phase source and carry the load. In this case, even though the phase currents are not balanced, the remaining two modules will continue to operate properly.

In similar fashion, more than three modules may be operated from a three-phase power source. For example, UNIPOWER Telecom also makes four-module, 23-inch shelves. Again, even though the phase currents are unbalanced, the units will operate properly. If more than four modules are operated, the units should be distributed evenly around the three phases.

UNIPOWER's RRS2U-19 rack/shelf has all module DC outputs internally connected in parallel while the AC inputs for each module are separate and isolated. This is true of all UNIPOWER racks and shelves.



Figure 1. Model RRS2U-19 Three-Unit Rack/Shelf with Power/Rectifier Module

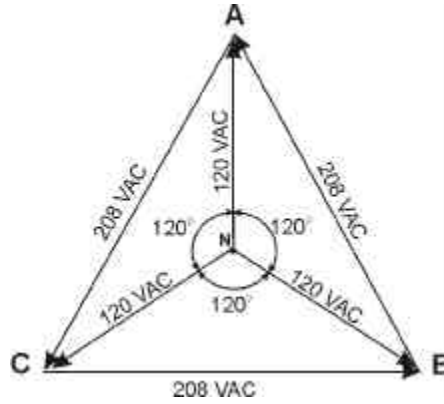

Figure 2. Phasor Diagram for North American 120/208 VAC 3-Phase Power

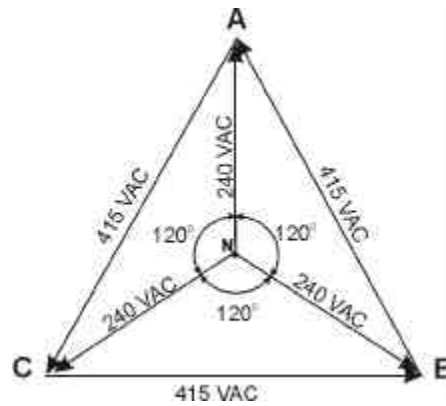

Figure 3. Phasor Diagram for European (U.K.) 240/415 VAC 3-Phase Power

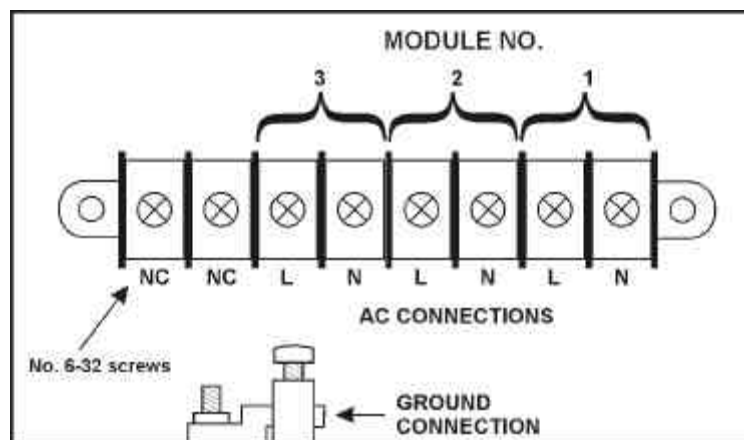

Figure 4. AC Input Connections for RRS2U-19 Three-Unit Rack/Shelf

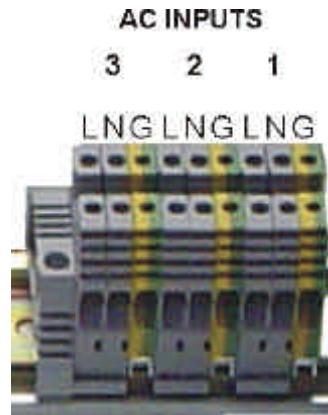

Figure 5. Connections to Gravitas X150/X300 Compact, Integrated DC Power Systems.

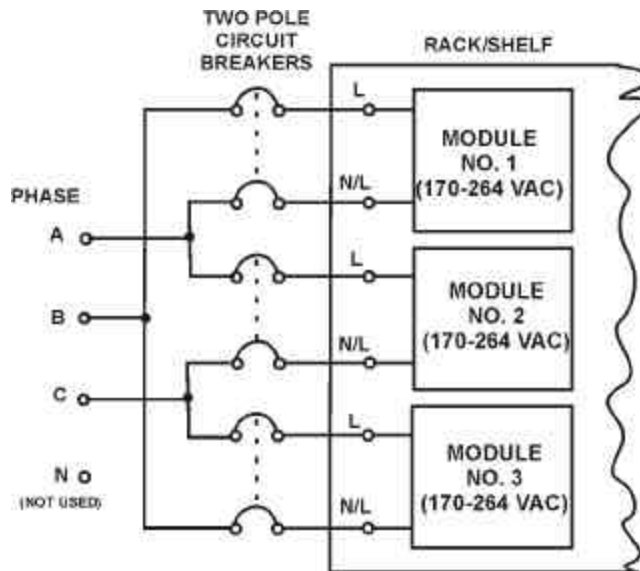

Figure 6. Delta Connection to 120/208 VAC 3-Phase Power Source

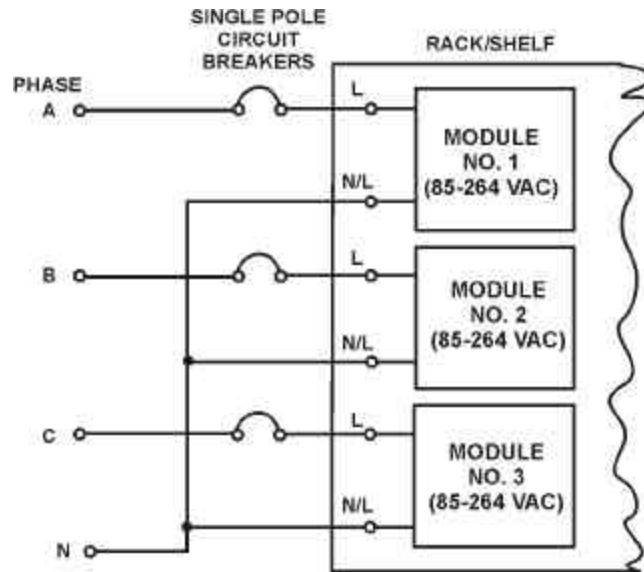

Figure 7. Wye Connection to 120/208 or 240/415 VAC 3-Phase Power Source